

THE DIMENSIONS SHOWN ON THIS DESIGNED DRAWING ARE FOR ILLUSTRATIVE PURPOSE

DIMENSIONS FOR ACTUAL CARRIER TAPE MAY SLIGHTLY DIFFERENT

REV.	MODIFICATION	DATE	DRAWING	CHECKED	APPROVED
1					
2					

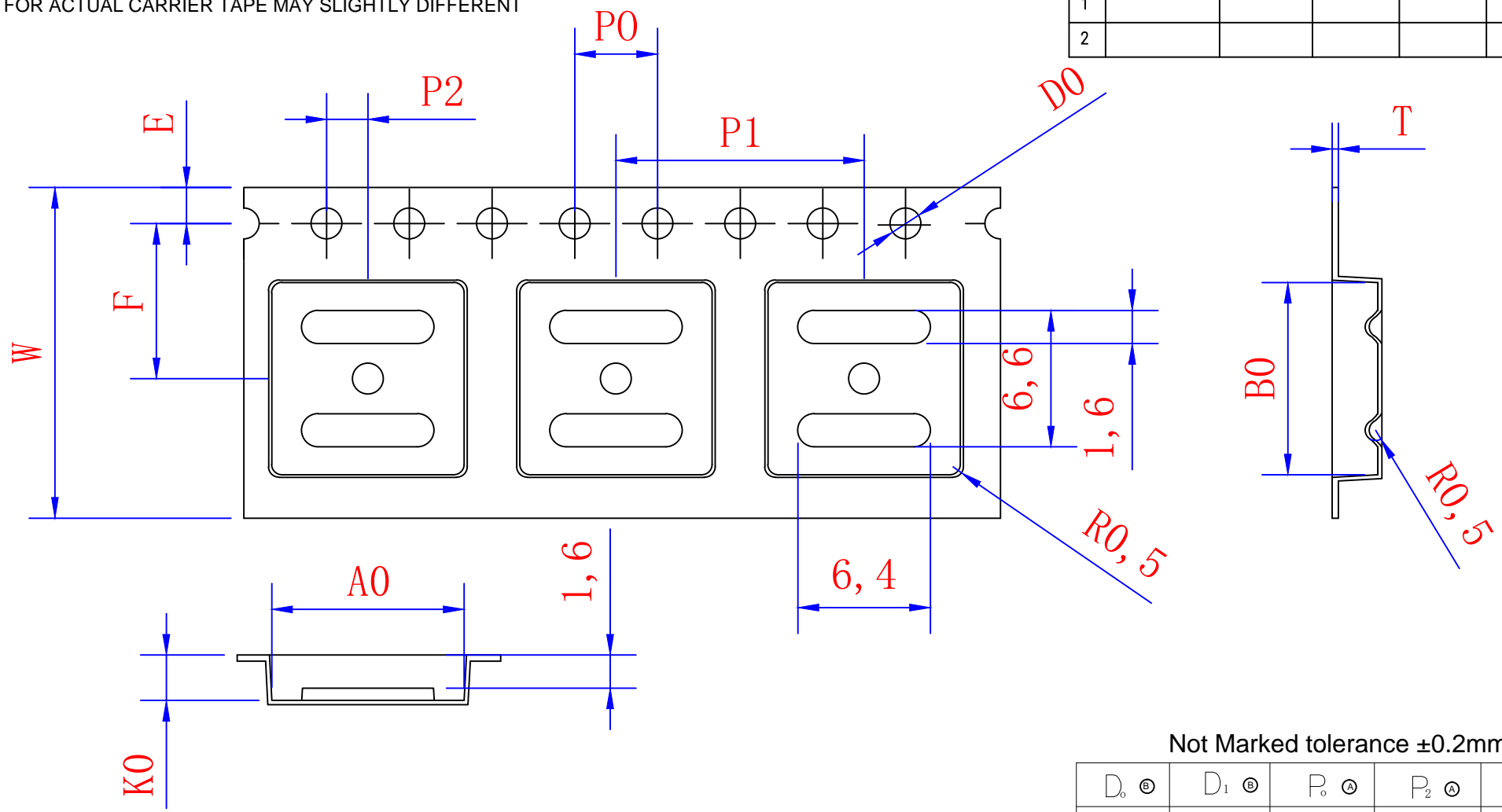

Not Marked tolerance ±0.2mm

D <sub>0</sub> ⊕	D <sub>1</sub> ⊕	P <sub>0</sub> ⊕	P <sub>2</sub> ⊕	E ⊕						
1.50 <sup>+0.10</sup> <sub>-0.00</sub>	1.50 <sup>+0.10</sup> <sub>-0.00</sub>	4.00 <sub>±0.10</sub>	2.00 <sub>±0.10</sub>	1.75 <sub>±0.10</sub>						
ITEM	W ⊕	A <sub>0</sub> ⊕	A <sub>1</sub> ⊕	B <sub>0</sub> ⊕	B <sub>1</sub> ⊕	K <sub>0</sub> ⊕	K <sub>1</sub> ⊕	P <sub>1</sub> ⊕	F ⊕	T ⊕
DIM	16.00 <sub>±0.30</sub>	9.30 <sub>±0.10</sub>	<sub>±0.10</sub>	9.30 <sub>±0.10</sub>	<sub>±0.10</sub>	2.20 <sub>±0.10</sub>	<sub>±0.10</sub>	12.00 <sub>±0.10</sub>	7.50 <sub>±0.10</sub>	0.30 <sub>±0.05</sub>
ALTERNATE										

- 1.The Maximum cumulative tolerance is ±0.2mm for 10 sprocket hole pitch
- 2.Cambers do not exceed 1.0mm in 250mm length
- 3.All dimension follow EIA-481-D series definition
- 4.Material: PS black
- 5.One 22" Reel=90 Meters

RoHS Compliance	NAME.	CARRIER TAPE	Part Number	Q07X07-B	SIZE	A4	DSGD		DIM TOL	Ang Tol
	Mold Ref	9.30x9.30x2.20	Customer P/N		SHEET	1/1	PROJ		X ±0.30 X.XX ±0.10 X ±5'	.X ±3'
	MATERIAL	PS BLACK	SCALE	1:1	REV	A/0	CHKD		X.X ±0.20X.XXX ±0.05 .XX ±1'	
			UNIT	MM	DATE	2022-05-16	APPD			