

THE DIMENSIONS SHOWN ON THIS DESIGNED DRAWING ARE FOR ILLUSTRATIVE PURPOSE

DIMENSIONS FOR ACTUAL CARRIER TAPE MAY SLIGHTLY DIFFERENT

REV.	MODIFICATION	DATE	DRAWING	CHECKED	APPROVED
1					
2					

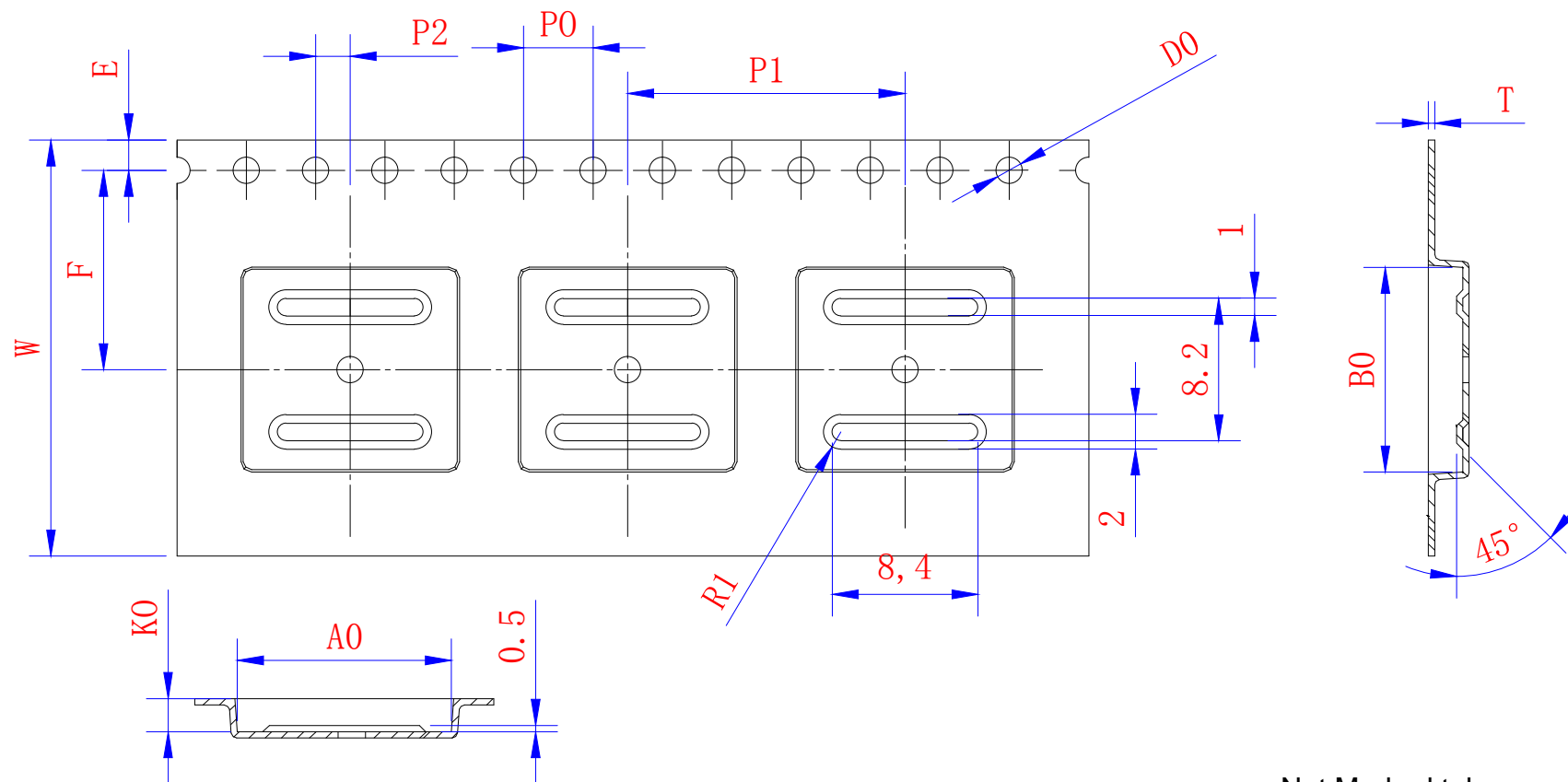

Not Marked tolerance $\pm 0.2\text{mm}$

$D_0 \text{ } \textcircled{E}$	$D_1 \text{ } \textcircled{E}$	$P_0 \text{ } \textcircled{A}$	$P_2 \text{ } \textcircled{A}$	$E \text{ } \textcircled{A}$						
1.50 $\begin{matrix} +0.10 \\ -0.00 \end{matrix}$	1.50 $\begin{matrix} +0.10 \\ -0.00 \end{matrix}$	4.00 ± 0.10	2.00 ± 0.10	1.75 ± 0.10						
ITEM	W \textcircled{E}	A ₀ \textcircled{A}	A ₁ \textcircled{A}	B ₀ \textcircled{A}	B ₁ \textcircled{A}	K ₀ \textcircled{C}	K ₁ \textcircled{C}	P ₁ \textcircled{A}	F \textcircled{A}	T \textcircled{E}
DIM	24.00 ± 0.30	12.35 ± 0.10	± 0.10	12.35 ± 0.10	± 0.10	1.85 ± 0.10	1.35 ± 0.10	16.00 ± 0.10	11.50 ± 0.10	0.30 ± 0.05
ALTERNATE										

- 1.The Maximum cumulative tolerance is $\pm 0.2\text{mm}$ for 10 sprocket hole pitch
- 2.Cambers do not exceed 1.0mm in 250mm length
- 3.All dimension follow EIA-481-D series definition
- 4.Material: PS black
- 5.One 22" Reel=90 Meters

RoHS Compliance	NAME.	CARRIER TAPE	Part Number	TQFP10101.0C	SIZE	A4	DSGD		DIM TOL	Ang Tol
	Mold Ref	12.35*12.35*1.85	Customer P/N		SHEET	1/1	PROJ		X ± 0.30	X.XX ± 0.10
	MATERIAL	PS BLACK	SCALE	1:1	REV	A/0	CHKD		X.X ± 0.20	X.XX ± 0.05
			UNIT	MM	DATE	2021.6.8	APPD			

