

THE DIMENSIONS SHOWN ON THIS DESIGNED DRAWING ARE FOR ILLUSTRATIVE PURPOSE
 DIMENSIONS FOR ACTUAL CARRIER TAPE MAY SLIGHTLY DIFFERENT

REV.	MODIFICATION	DATE	DRAWING	CHECKED	APPROVED
1					
2					

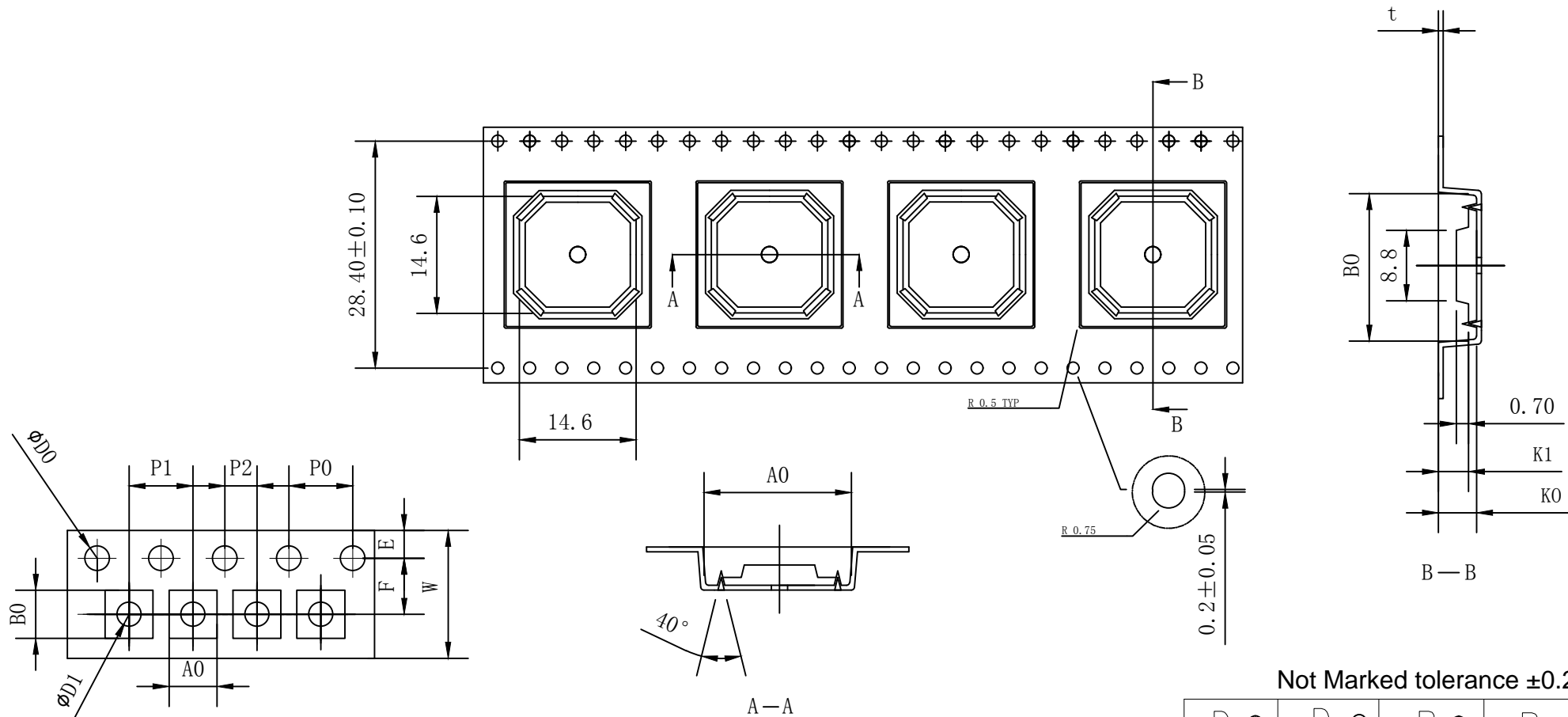

Not Marked tolerance ±0.2mm

D ₀ ⊕	D ₁ ⊕	P ₀ ⊕	P ₂ ⊕	E ⊕						
1.50 ^{+0.10} _{-0.00}	2.00 ^{+0.10} _{-0.00}	4.00 ±0.10	2.00 ±0.10	1.75 ±0.10						
ITEM	W ⊕	A ₀ ⊕	A ₁ ⊕	B ₀ ⊕	B ₁ ⊕	K ₀ ⊕	K ₁ ⊕	P ₁ ⊕	F ⊕	T ⊕
DIM	32.00 ±0.30	18.00 ±0.10	±0.10	18.00 ±0.10	±0.10	3.00 ±0.10	2.20 ±0.10	24.00 ±0.10	14.20 ±0.10	0.35 ±0.05
ALTERNATE										

- 1.The Maximum cumulative tolerance is ±0.2mm for 10 sprocket hole pitch
- 2.Cambers do not exceed 1.0mm in 250mm length
- 3.All dimension follow EIA-481-D series definition
- 4.Material: PS black
- 5.One 22" Level Wind Reel=136 Meters

RoHS Compliance	NAME.	CARRIER TAPE	Part Number	Q14X14-C	SIZE	A4	DSGD		DIM TOL	Ang Tol
	Mold Ref	18.00*18.00*3.00	Customer P/N		SHEET	1/1	PROJ		X ±0.30 X.XX ±0.10 X ±5'	X ±3'
	MATERIAL	PS BLACK	SCALE	1:1	REV	A/0	CHKD		X.X ±0.20X.XXX ±0.05 .XX ±1'	
			UNIT	MM	DATE	2022.01.17	APPD			

