

THE DIMENSIONS SHOWN ON THIS DESIGNED DRAWING ARE FOR ILLUSTRATIVE PURPOSE

DIMENSIONS FOR ACTUAL CARRIER TAPE MAY SLIGHTLY DIFFERENT

REV.	MODIFICATION	DATE	DRAWING	CHECKED	APPROVED
1					
2					

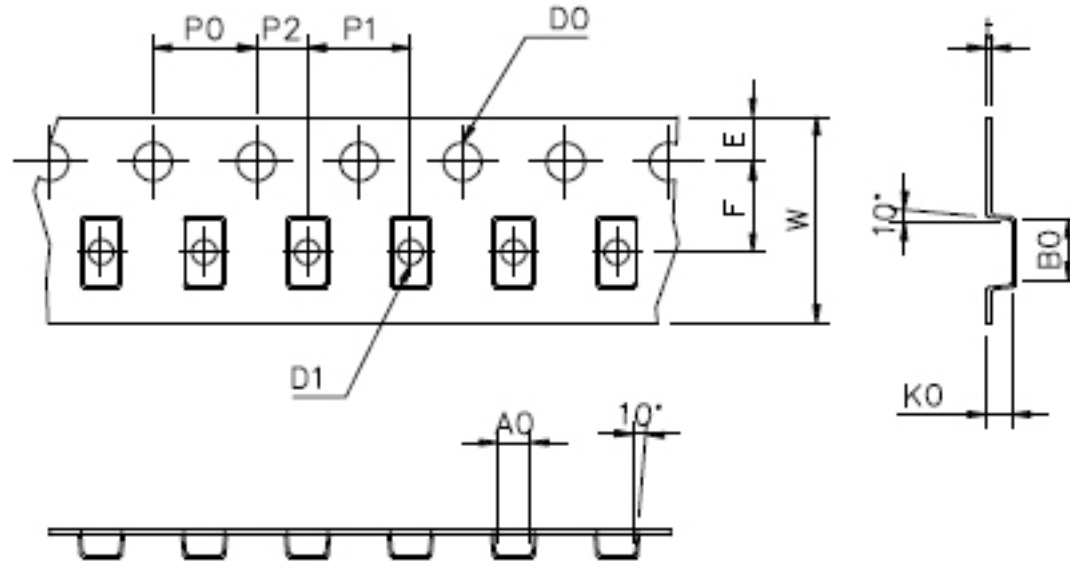

Not Marked tolerance  $\pm 0.2\text{mm}$

$D_0$ $\text{\textcircled{E}}$	$D_1$ $\text{\textcircled{E}}$	$P_0$ $\text{\textcircled{A}}$	$P_1$ $\text{\textcircled{A}}$	$P_2$ $\text{\textcircled{A}}$	$E$ $\text{\textcircled{A}}$					
1.55 $\pm 0.05$	below 1.20	4.00 $\pm 0.10$	2.00 $\pm 0.05$	2.00 $\pm 0.05$	1.75 $\pm 0.10$					
ITEM	$W$ $\text{\textcircled{E}}$	$A_0$ $\text{\textcircled{A}}$	$A_1$ $\text{\textcircled{A}}$	$B_0$ $\text{\textcircled{A}}$	$B_1$ $\text{\textcircled{A}}$	$K_0$ $\text{\textcircled{C}}$	$K_1$ $\text{\textcircled{C}}$	$P_1$ $\text{\textcircled{A}}$	$F$ $\text{\textcircled{A}}$	$T$ $\text{\textcircled{E}}$
DIM	8.00 $\pm 0.10$	2.30 $\pm 0.10$	$\pm 0.10$	2.90 $\pm 0.10$	$\pm 0.10$	1.10 $\pm 0.10$	$\pm 0.10$	4.00 $\pm 0.10$	3.50 $\pm 0.05$	0.22 $\pm 0.05$
ALTERNATE										

- The Maximum cumulative tolerance is  $\pm 0.2\text{mm}$  for 10 sprocket hole pitch
- Cambers do not exceed 1.0mm in 250mm length
- All dimension follow EIA-481-D series definition
- Material: PC+S black conductive
- One 22" Reel=1,000 Meters

RoHS Compliance	NAME.	CARRIER TAPE	Mold Ref	SZ008	SIZE	A4	DSGD		DIM TOL	Ang Tol
	Mold Ref	2.30*2.90*1.10	Customer P/N		SHEET	1/1	PROJ		X $\pm 0.30$	X.XX $\pm 0.10$
	MATERIAL	PS BLACK	SCALE	1:1	REV	A/0	CHKD		X.X $\pm 0.20$	X.XX $\pm 0.05$
			UNIT	MM	DATE	2018.7.5	APPD			

