

PLASTIC REEL DATA SHEET

SHPR series Antistatic PLASTIC REEL

Product Description

SINHO Antistatic PLASTIC REEL SHPR series is made of HIPS materials

Available Widths

SHPR series is available in the standard sizes of 4"xwide 8mm, 4"xwide 12mm, 4"xwide 16mm

Detail Specs

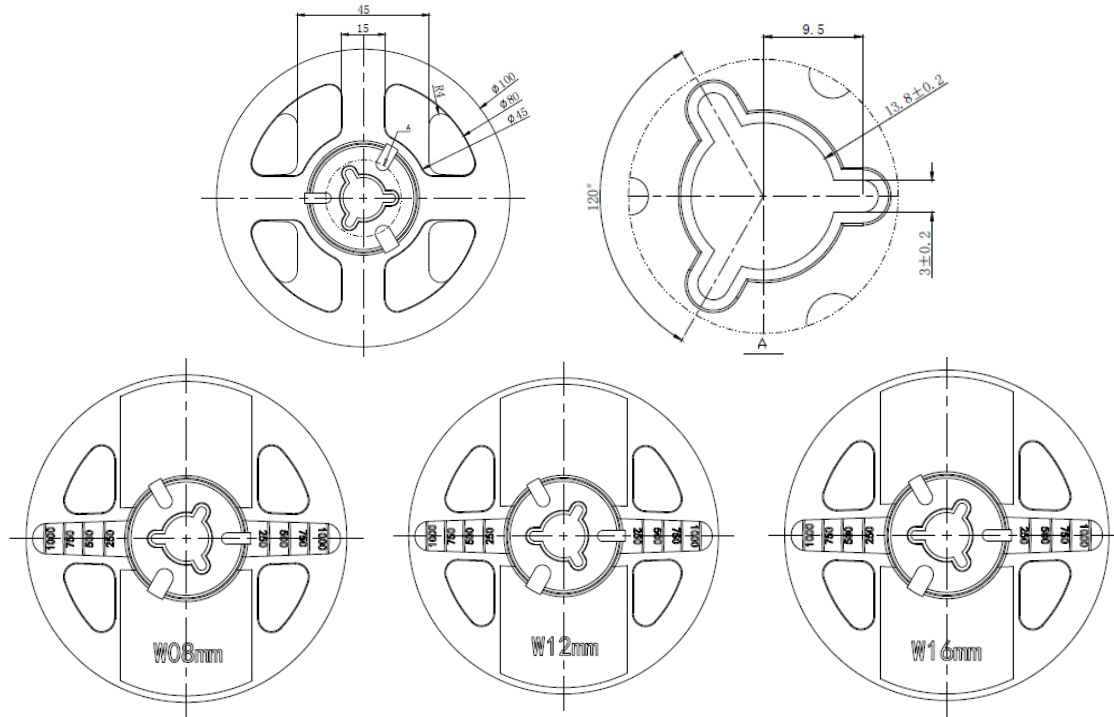

ELECTRICAL PROPERTIES	TYPICAL VALUE	TEST METHOD
Surface Resistivity	$\leq 10^{11}\Omega$	ASTM-D257, Ω
PHYSICAL PROPERTIES	TYPICAL VALUE	TEST METHOD
Appearance:	Black	/

Note: The technical information and data presented here should be considered representative or typical only, and should not be used for specification purposes.

Remark:

The customer should determine their own product's application based on each of their own internal criteria and machine type

Storage Conditions:

1. Environment Temperature and relative humidity: 20 °C-30 °C,(50%±10%) RH
2. Shelf Life: 1 year
3. Be protected from direct sunlight

Rev #: SHPR series
PRINTED IN XIAMEN

Revision Data: 2012-1-1
TZJ

WHEN YOU HAVE QUESTION WITH DATA SHEET,WE COMPOUND THE ANSWER.

SINHO ELECTRONIC TECHNOLOGY CO.,LTD
West side of 27th building. Huli industrial. Xiamen City,China.
Tel: 0086-592-5635133 Fax: 0086-592-5750437
Email: Info@xmsinho.com