

**PLASTIC REEL DATA SHEET**

**SHPR series Antistatic PLASTIC REEL**

**Product Description**

SINHO Antistatic PLASTIC REEL SHPR series is made of HIPS materials

**Available Widths**

SHPR series is available in the standard sizes of 15"×wide 12mm, 15"×wide 16mm, 15"×wide 24mm

15"×wide 32mm, 15"×wide 44mm, 15"×wide 56mm, 15"×wide 72mm, they are in assembly types (two flanges plus hub)

**Detail Specs**

**15" flange**

**4" hub**

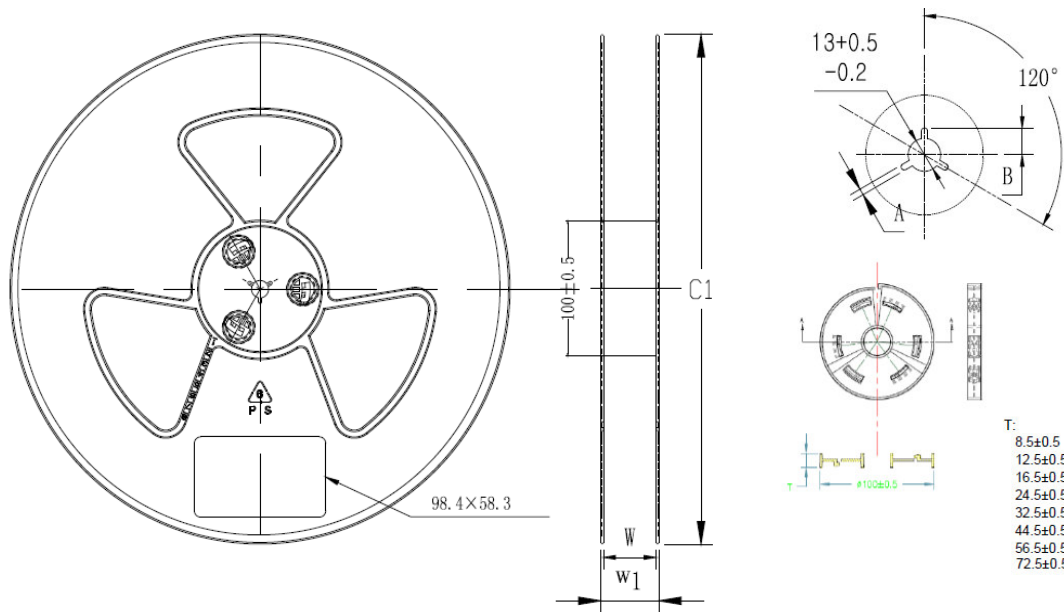

ELECTRICAL PROPERTIES	TYPICAL VALUE	TEST METHOD
Surface Resistivity	$\leq 10^{11} \Omega$	ASTM-D257, $\Omega$
PHYSICAL PROPERTIES	TYPICAL VALUE	TEST METHOD
Appearance:	Blue	/
Note: The technical information and data presented here should be considered representative or typical only, and should not be used for specification purposes.		

**Remark:**

The customer should determine their own product's application based on each of their own internal criteria and machine type

**Storage Conditions:**

1. Environment Temperature and relative humidity: 20°C-30°C, (50%±10%) RH
2. Shelf Life: 1 year
3. Be protected from direct sunlight

Rev #: SHPR series  
PRINTED IN XIAMEN

Revision Data: 2012-1-1  
TZJ

WHEN YOU HAVE QUESTION WITH DATA SHEET, WE COMPOUND THE ANSWER.

SINHO ELECTRONIC TECHNOLOGY CO.,LTD  
West side of 27th building. Huli industrial. Xiamen City, China.  
Tel: 0086-592-5635133 Fax: 0086-592-5750437  
Email: Info@xmsinho.com