

THE DIMENSIONS SHOWN ON THIS DESIGNED DRAWING ARE FOR ILLUSTRATIVE PURPOSE
 DIMENSIONS FOR ACTUAL CARRIER TAPE MAY SLIGHTLY DIFFERENT

REV.	MODIFICATION	DATE	DRAWING	CHECKED	APPROVED
1					

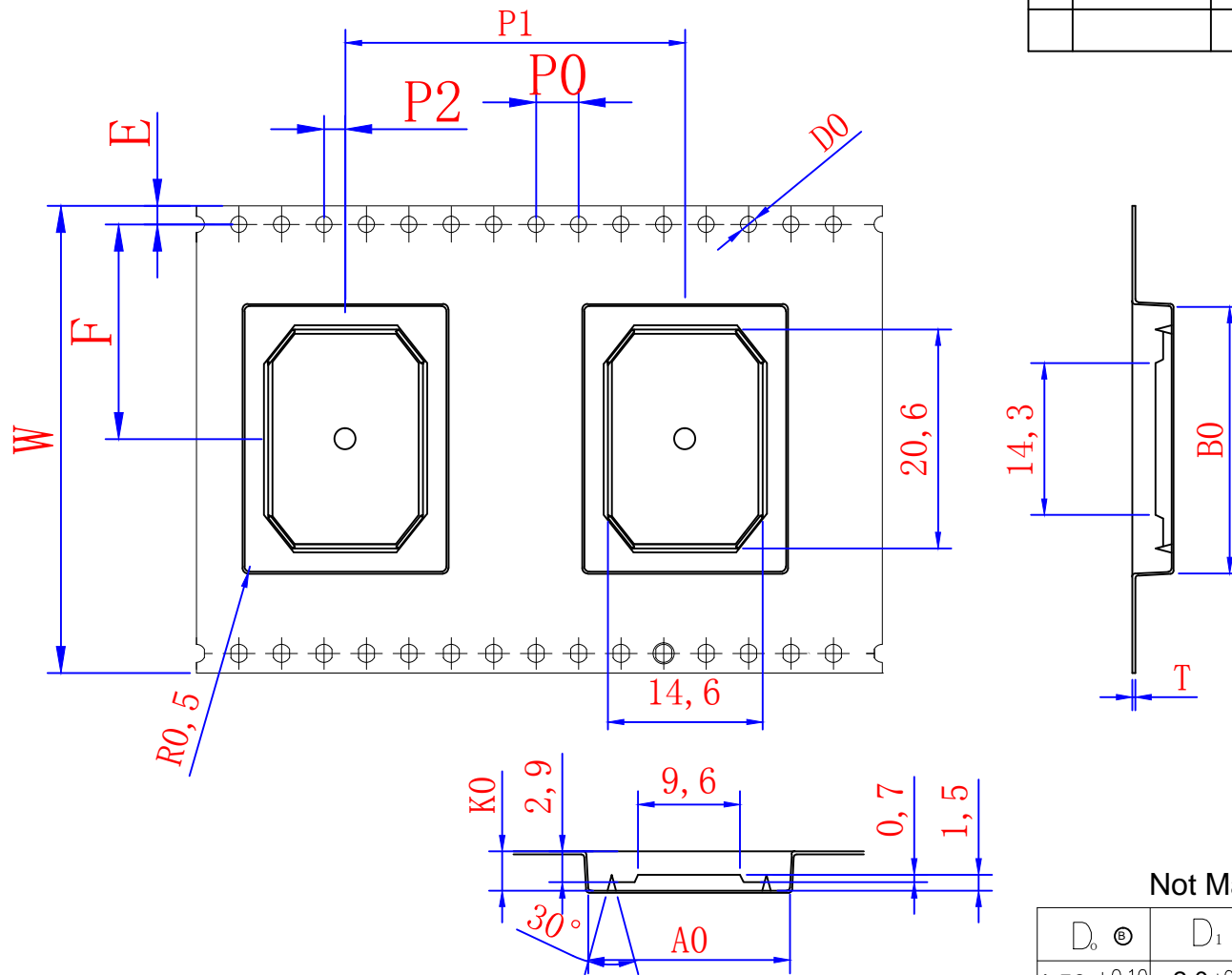

Not Marked tolerance $\pm 0.2\text{mm}$

$D_0 \text{ } \textcircled{E}$	$D_1 \text{ } \textcircled{E}$	$P_0 \text{ } \textcircled{A}$	$P_2 \text{ } \textcircled{A}$	$E \text{ } \textcircled{A}$						
1.50 $\begin{smallmatrix} +0.10 \\ -0.00 \end{smallmatrix}$	2.0 $\begin{smallmatrix} +0.10 \\ -0.00 \end{smallmatrix}$	4.00 ± 0.10	2.00 ± 0.10	1.75 ± 0.10						
$K_0 \text{ } \textcircled{C}$	$K_1 \text{ } \textcircled{C}$	$P_1 \text{ } \textcircled{A}$	$F \text{ } \textcircled{A}$	$T \text{ } \textcircled{E}$						
3.70 ± 0.10	2.90 ± 0.10	32.00 ± 0.10	20.20 ± 0.10	0.30 ± 0.05						
ITEM	W \textcircled{E}	$A_0 \text{ } \textcircled{A}$	$A_1 \text{ } \textcircled{A}$	$B_0 \text{ } \textcircled{A}$	$B_1 \text{ } \textcircled{A}$	$K_0 \text{ } \textcircled{C}$	$K_1 \text{ } \textcircled{C}$	$P_1 \text{ } \textcircled{A}$	$F \text{ } \textcircled{A}$	$T \text{ } \textcircled{E}$
DIM	44.00 ± 0.30	19.00 ± 0.10	± 0.10	25.00 ± 0.10	± 0.10	3.70 ± 0.10	2.90 ± 0.10	32.00 ± 0.10	20.20 ± 0.10	0.30 ± 0.05
ALTERNATE										

- The Maximum cumulative tolerance is $\pm 0.2\text{mm}$ for 10 sprocket hole pitch
- Cambers do not exceed 1.0mm in 250mm length
- All dimension follow EIA-481-D series definition
- Material: PS black
- One 22" Reel=55 Meters

RoHS Compliance	NAME.	CARRIER TAPE	Part Number	Q14X20-J	SIZE	A4	DSGD		DIM TOL	Ang Tol
	Mold Ref	19.00*25.00*3.70	Customer P/N		SHEET	1/1	PROJ		X ± 0.30	X.XX ± 0.10
	MATERIAL	PS BLACK	SCALE	1:1	REV	A/0	CHKD		X.X ± 0.20	X.XX ± 0.05
			UNIT	MM	DATE	2022.01.17	APPD			

