

THE DIMENSIONS SHOWN ON THIS DESIGNED DRAWING ARE FOR ILLUSTRATIVE PURPOSE

DIMENSIONS FOR ACTUAL CARRIER TAPE MAY SLIGHTLY DIFFERENT

REV.	MODIFICATION	DATE	DRAWING	CHECKED	APPROVED
1					
2					

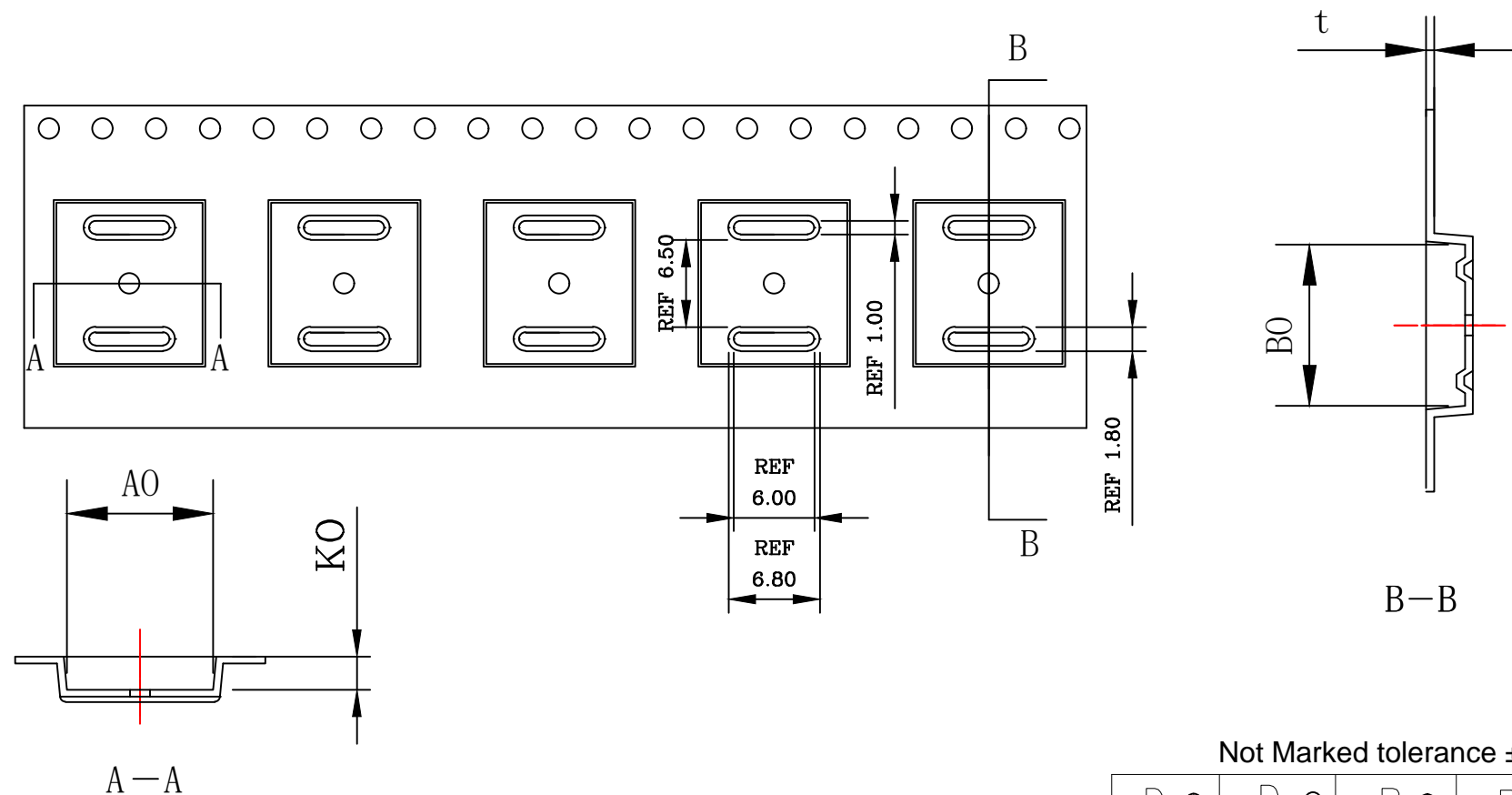

Not Marked tolerance  $\pm 0.2\text{mm}$

- 1.The Maximum cumulative tolerance is  $\pm 0.2\text{mm}$  for 10 sprocket hole pitch
- 2.Cambers do not exceed 1.0mm in 250mm length
- 3.All dimension follow EIA-481-D series definition
- 4.Material: PS black
- 5.One 22" Reel=62 Meters

	$D_0 \text{ } \textcircled{E}$	$D_1 \text{ } \textcircled{E}$	$P_0 \text{ } \textcircled{A}$	$P_2 \text{ } \textcircled{A}$	$E \text{ } \textcircled{A}$					
	1.50 $\begin{smallmatrix} +0.10 \\ -0.00 \end{smallmatrix}$	1.50 $\begin{smallmatrix} +0.10 \\ -0.00 \end{smallmatrix}$	4.00 $\pm 0.10$	2.00 $\pm 0.10$	1.75 $\pm 0.10$					
ITEM	$W \text{ } \textcircled{E}$	$A_0 \text{ } \textcircled{A}$	$A_1 \text{ } \textcircled{A}$	$B_0 \text{ } \textcircled{A}$	$B_1 \text{ } \textcircled{A}$	$K_0 \text{ } \textcircled{C}$	$K_1 \text{ } \textcircled{C}$	$P_1 \text{ } \textcircled{A}$	$F \text{ } \textcircled{A}$	$T \text{ } \textcircled{E}$
DIM	24.00 $\pm 0.30$	10.90 $\pm 0.10$	$\pm 0.10$	12.00 $\pm 0.10$	$\pm 0.10$	3.20 $\pm 0.10$	2.80 $\pm 0.10$	16.00 $\pm 0.10$	11.50 $\pm 0.10$	0.30 $\pm 0.05$
ALTERNATE										

RoHS Compliance	NAME.	CARRIER TAPE	Part Number	SO18W4	SIZE	A4	DSGD		DIM TOL	Ang Tol
	Mold Ref	10.90*12.00*3.20	Customer P/N		SHEET	1/1	PROJ		X $\pm 0.30$ X.XX $\pm 0.10$ X $\pm 5'$	X $\pm 3'$
	MATERIAL	PS BLACK	SCALE	1:1	REV	A/0	CHKD		X.X $\pm 0.20$ X.XXX $\pm 0.05$ .XX $\pm 1'$	.XX $\pm 1'$
			UNIT	MM	DATE	2021.11.23	APPD			