

THE DIMENSIONS SHOWN ON THIS DESIGNED DRAWING ARE FOR ILLUSTRATIVE PURPOSE  
 DIMENSIONS FOR ACTUAL CARRIER TAPE MAY SLIGHTLY DIFFERENT

REV.	MODIFICATION	DATE	DRAWING	CHECKED	APPROVED
1					
2					

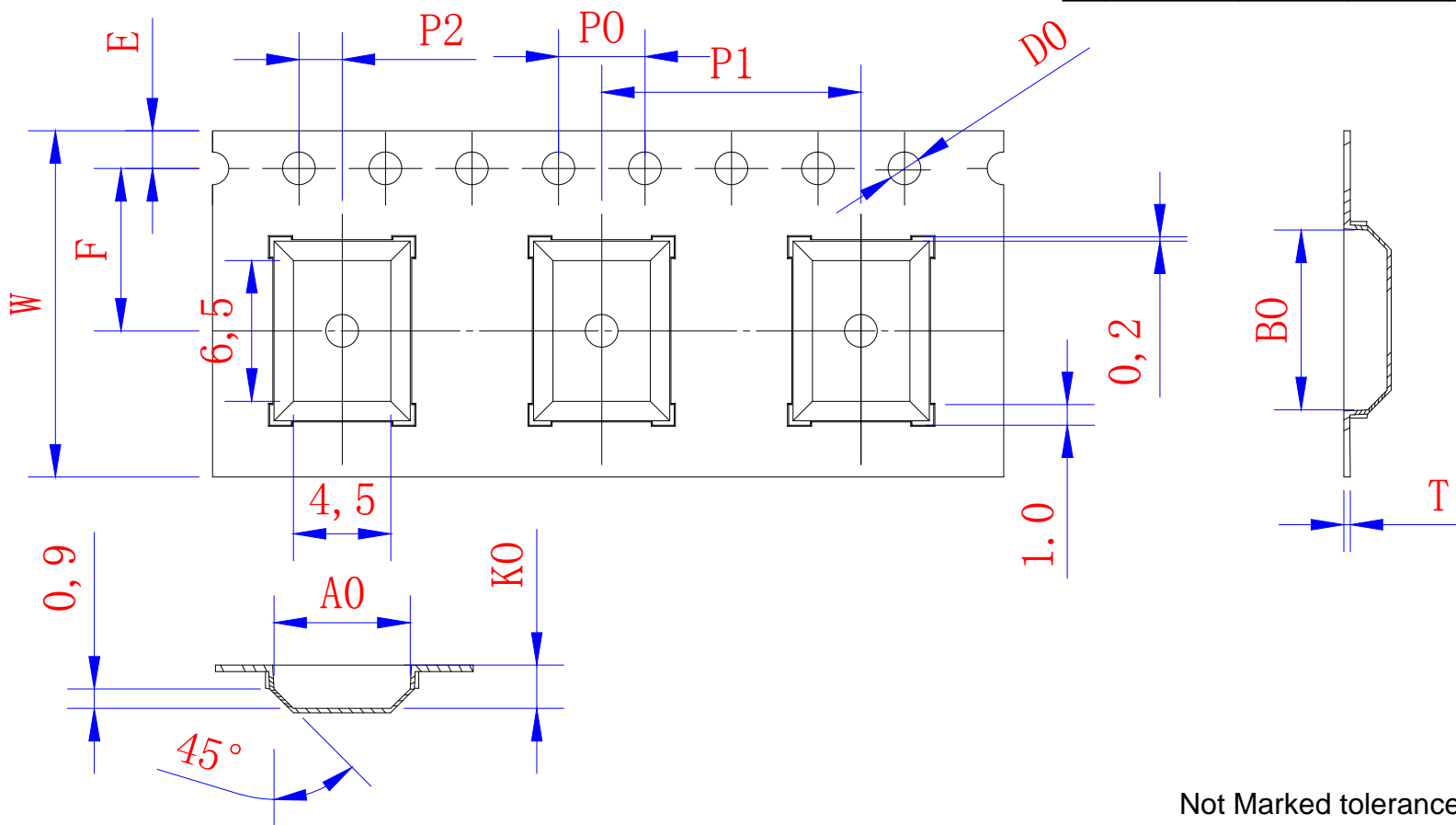

Not Marked tolerance  $\pm 0.2\text{mm}$

- The Maximum cumulative tolerance is  $\pm 0.2\text{mm}$  for 10 sprocket hole pitch
- Cambers do not exceed 1.0mm in 250mm length
- All dimension follow EIA-481-D series definition
- Material: PS black
- One 22" Reel=96 Meters

	$D_0 \text{ } \textcircled{E}$	$D_1 \text{ } \textcircled{E}$	$P_0 \text{ } \textcircled{A}$	$P_2 \text{ } \textcircled{A}$	$E \text{ } \textcircled{A}$					
	$1.50 \begin{matrix} +0.10 \\ -0.00 \end{matrix}$	$1.50 \begin{matrix} +0.10 \\ -0.00 \end{matrix}$	$4.00 \pm 0.10$	$2.00 \pm 0.10$	$1.75 \pm 0.10$					
ITEM	$W \text{ } \textcircled{E}$	$A_0 \text{ } \textcircled{A}$	$A_1 \text{ } \textcircled{A}$	$B_0 \text{ } \textcircled{A}$	$B_1 \text{ } \textcircled{A}$	$K_0 \text{ } \textcircled{C}$	$K_1 \text{ } \textcircled{C}$	$P_1 \text{ } \textcircled{A}$	$F \text{ } \textcircled{A}$	$T \text{ } \textcircled{E}$
DIM	$16.00 \pm 0.30$	$6.30 \pm 0.10$	$\pm 0.10$	$8.30 \pm 0.10$	$\pm 0.10$	$2.00 \pm 0.10$	$1.10 \pm 0.10$	$12.00 \pm 0.10$	$7.50 \pm 0.10$	$0.30 \pm 0.05$
ALTERNATE										

RoHS Compliance	NAME.	CARRIER TAPE	Part Number	BGA0608C	SIZE	A4	DSGD		DIM TOL	Ang Tol	
	Mold Ref	6.30*8.30*2.00	Customer P/N		SHEET	1/1	PROJ		$X \pm 0.30$	$X.XX \pm 0.10$	$X \pm 5'$
	MATERIAL	PS BLACK	SCALE	1:1	REV	A/0	CHKD		$X.X \pm 0.20$	$.XXX \pm 0.05$	$.XX \pm 3'$
			UNIT	MM	DATE	2021.6.8	APPD				