

THE DIMENSIONS SHOWN ON THIS DESIGNED DRAWING ARE FOR ILLUSTRATIVE PURPOSE

DIMENSIONS FOR ACTUAL CARRIER TAPE MAY SLIGHTLY DIFFERENT

REV.	MODIFICATION	DATE	DRAWING	CHECKED	APPROVED
1					
2					

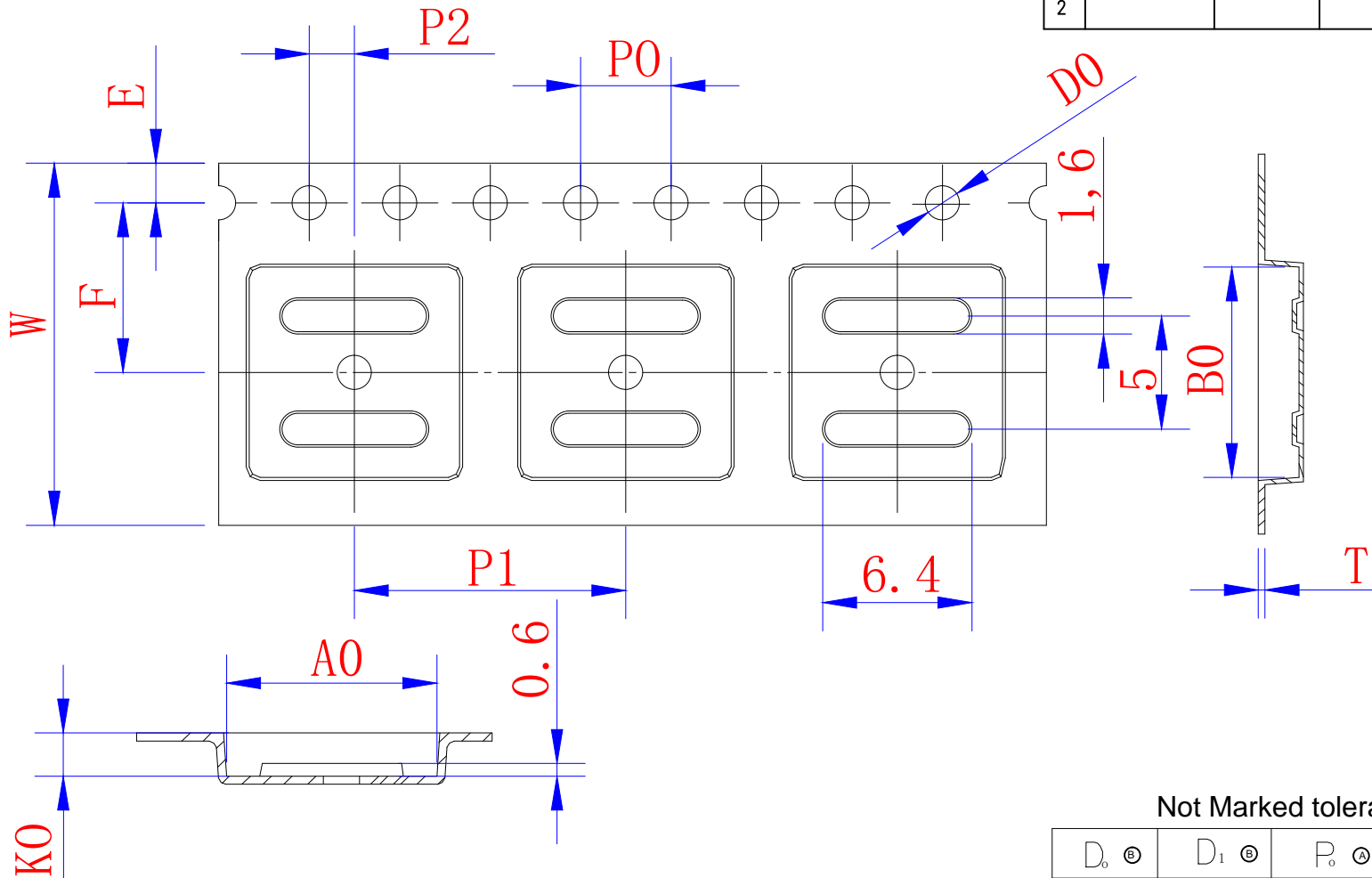

Not Marked tolerance $\pm 0.2\text{mm}$

D_0 $\text{\textcircled{E}}$	D_1 $\text{\textcircled{E}}$	P_0 $\text{\textcircled{A}}$	P_2 $\text{\textcircled{A}}$	E $\text{\textcircled{A}}$						
1.50 $\begin{matrix} +0.10 \\ -0.00 \end{matrix}$	1.50 $\begin{matrix} +0.10 \\ -0.00 \end{matrix}$	4.00 ± 0.10	2.00 ± 0.10	1.75 ± 0.10						
ITEM	W $\text{\textcircled{E}}$	A_0 $\text{\textcircled{A}}$	A_1 $\text{\textcircled{A}}$	B_0 $\text{\textcircled{A}}$	B_1 $\text{\textcircled{A}}$	K_0 $\text{\textcircled{C}}$	K_1 $\text{\textcircled{C}}$	P_1 $\text{\textcircled{A}}$	F $\text{\textcircled{A}}$	T $\text{\textcircled{E}}$
DIM	16.00 ± 0.30	9.30 ± 0.10	± 0.10	9.30 ± 0.10	± 0.10	1.80 ± 0.10	1.20 ± 0.10	12.00 ± 0.10	7.50 ± 0.10	0.30 ± 0.05
ALTERNATE										

- The Maximum cumulative tolerance is $\pm 0.2\text{mm}$ for 10 sprocket hole pitch
- Cambers do not exceed 1.0mm in 250mm length
- All dimension follow EIA-481-D series definition
- Material: PS black
- One 22" Reel=98 Meters

RoHS Compliance	NAME.	CARRIER TAPE	Part Number	TQFP07071.0E	SIZE	A4	DSGD		DIM TOL	Ang Tol	
	Mold Ref	9.30*9.30*1.80	Customer P/N		SHEET	1/1	PROJ		$X \pm 0.30$	$X.XX \pm 0.10$	$X \pm 5'$
	MATERIAL	PS BLACK	SCALE	1:1	REV	A/0	CHKD		$X.X \pm 0.20$	$X.XX \pm 0.05$	$.XX \pm 1'$
			UNIT	MM	DATE	2021.6.8	APPD				