

THE DIMENSIONS SHOWN ON THIS DESIGNED DRAWING ARE FOR ILLUSTRATIVE PURPOSE
 DIMENSIONS FOR ACTUAL CARRIER TAPE MAY SLIGHTLY DIFFERENT

REV.	MODIFICATION	DATE	DRAWING	CHECKED	APPROVED
1					
2					

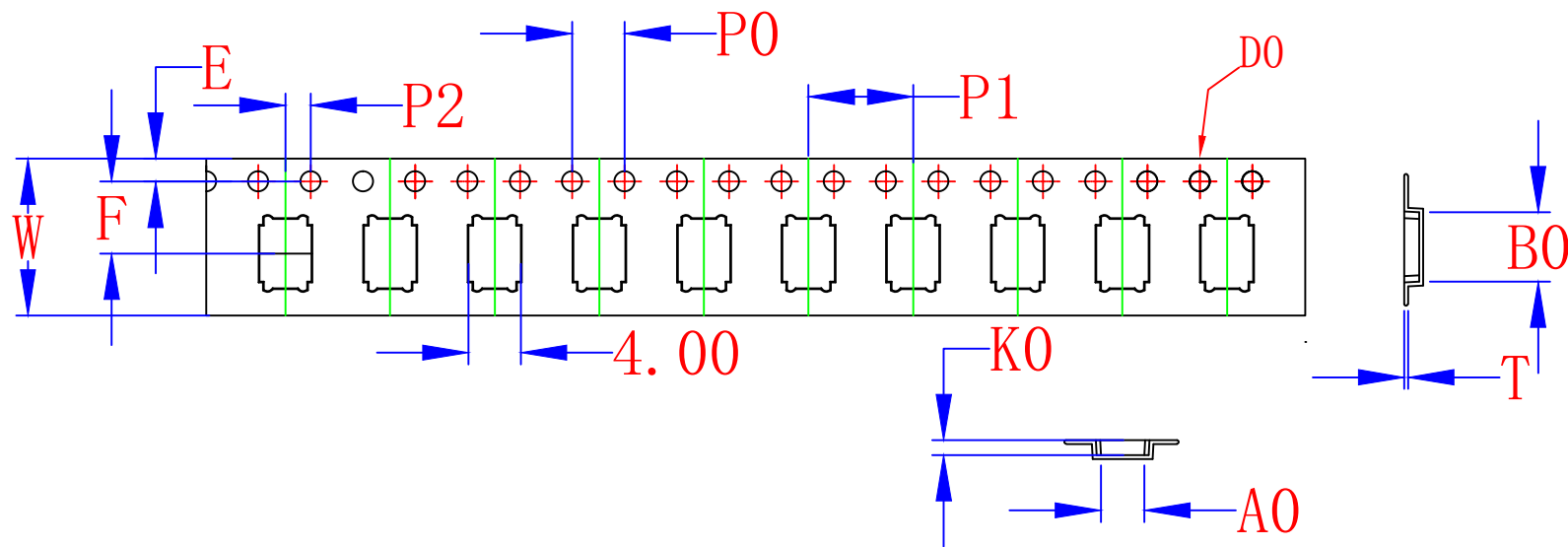

Not Marked tolerance $\pm 0.2\text{mm}$

	$D_0 \text{ } \textcircled{E}$	$D_1 \text{ } \textcircled{E}$	$P_0 \text{ } \textcircled{A}$	$P_2 \text{ } \textcircled{A}$	$E \text{ } \textcircled{A}$					
	$1.50 \begin{smallmatrix} +0.10 \\ -0.00 \end{smallmatrix}$	$1.50 \begin{smallmatrix} +0.10 \\ -0.00 \end{smallmatrix}$	4.00 ± 0.10	2.00 ± 0.10	1.75 ± 0.10					
ITEM	$W \text{ } \textcircled{E}$	$A_0 \text{ } \textcircled{A}$	$A_1 \text{ } \textcircled{A}$	$B_0 \text{ } \textcircled{A}$	$B_1 \text{ } \textcircled{A}$	$K_0 \text{ } \textcircled{C}$	$K_1 \text{ } \textcircled{C}$	$P_1 \text{ } \textcircled{A}$	$F \text{ } \textcircled{A}$	$T \text{ } \textcircled{E}$
DIM	12.00 ± 0.30	3.30 ± 0.10	± 0.10	5.30 ± 0.10	± 0.10	1.15 ± 0.10	± 0.10	8.00 ± 0.10	5.50 ± 0.10	0.30 ± 0.05
ALTERNATE										

- 1.The Maximum cumulative tolerance is $\pm 0.2\text{mm}$ for 10 sprocket hole pitch
- 2.Cambers do not exceed 1.0mm in 250mm length
- 3.All dimension follow EIA-481-D series definition
- 4.Material: PS black
- 5.One 22" Reel=133 Meters

RoHS Compliance	NAME.	CARRIER TAPE	PN	QFN-3X5mm	SIZE	A4	DSGD		DIM TOL	Ang Tol	
	Mold Ref	3.30*5.30*1.15	Customer P/N		SHEET	1/1	PROJ		$X \pm 0.30$	$X.XX \pm 0.10$	$X \pm 5'$
	MATERIAL	PS BLACK	SCALE	1:1	REV	A/0	CHKD		$X.X \pm 0.20$	$.XXX \pm 0.05$	$.XX \pm 3'$
			UNIT	MM	DATE	2018.12.10	APPD				