

THE DIMENSIONS SHOWN ON THIS DESIGNED DRAWING ARE FOR ILLUSTRATIVE PURPOSE
 DIMENSIONS FOR ACTUAL CARRIER TAPE MAY SLIGHTLY DIFFERENT

| REV. | MODIFICATION | DATE | DRAWING | CHECKED | APPROVED |
|------|--------------|------|---------|---------|----------|
| 1 | | | | | |
| 2 | | | | | |

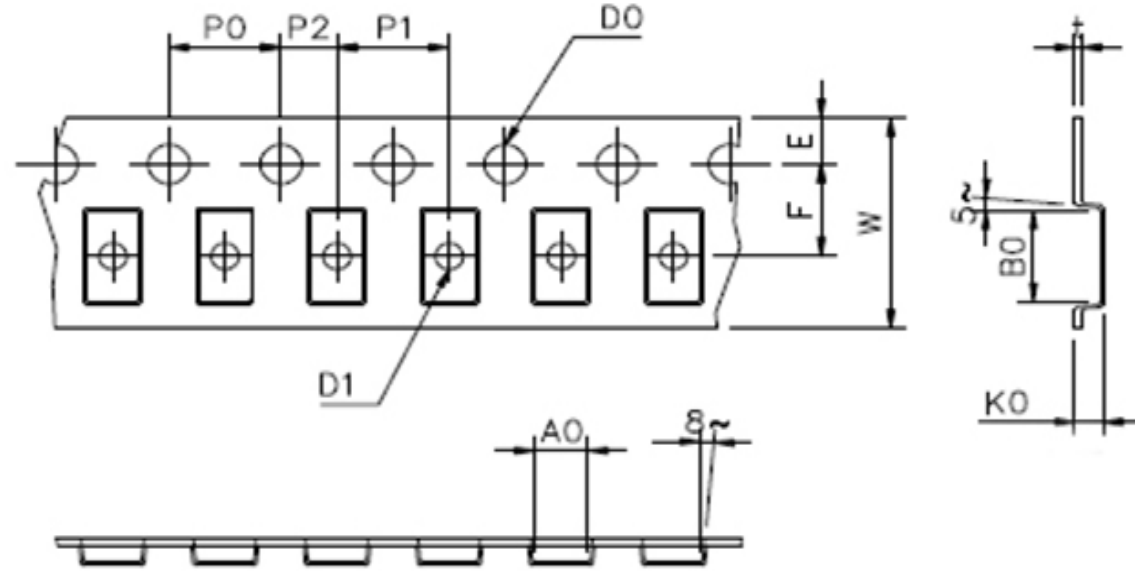

Not Marked tolerance $\pm 0.2\text{mm}$

| D_0 $\text{\textcircled{E}}$ | D_1 $\text{\textcircled{E}}$ | P_0 $\text{\textcircled{A}}$ | P_2 $\text{\textcircled{A}}$ | E $\text{\textcircled{A}}$ | | | | | | |
|--------------------------------|--------------------------------|--------------------------------|--------------------------------|--------------------------------|--------------------------------|--------------------------------|--------------------------------|--------------------------------|------------------------------|------------------------------|
| 1.55 ± 0.05 | 1.20 < 1.20 | 4.00 ± 0.10 | 2.00 ± 0.05 | 1.75 ± 0.10 | | | | | | |
| ITEM | W $\text{\textcircled{E}}$ | A_0 $\text{\textcircled{A}}$ | A_1 $\text{\textcircled{A}}$ | B_0 $\text{\textcircled{A}}$ | B_1 $\text{\textcircled{A}}$ | K_0 $\text{\textcircled{C}}$ | K_1 $\text{\textcircled{C}}$ | P_1 $\text{\textcircled{A}}$ | F $\text{\textcircled{A}}$ | T $\text{\textcircled{E}}$ |
| DIM | 8.00 ± 0.10 | 1.85 ± 0.10 | ± 0.10 | 3.45 ± 0.10 | ± 0.10 | 1.25 ± 0.10 | ± 0.10 | 4.00 ± 0.10 | 3.50 ± 0.05 | 0.22 ± 0.05 |
| ALTERNATE | | | | | | | | | | |

- The Maximum cumulative tolerance is $\pm 0.2\text{mm}$ for 10 sprocket hole pitch
- Cambers do not exceed 1.0mm in 250mm length
- All dimension follow EIA-481-D series definition
- Material: PC+S black conductive
- One 22" Reel=1,000 Meters

| | | | | | | | | | | |
|-----------------|----------|----------------|--------------|---------|-------|-----|------|--|--|--------------|
| RoHS Compliance | NAME. | CARRIER TAPE | Mold Ref | 1206-01 | SIZE | A4 | DSGD | | DIM TOL | Ang Tol |
| | Mold Ref | 1.85*3.45*1.25 | Customer P/N | | SHEET | 1/1 | PROJ | | X ± 0.30 X.XX ± 0.10 X $\pm 5'$ | X $\pm 3'$ |
| | MATERIAL | PS BLACK | SCALE | 1:1 | REV | A/0 | CHKD | | X.X ± 0.20 X.XXX ± 0.05 .XX $\pm 1'$ | .XX $\pm 1'$ |
| | | | UNIT | MM | DATE | | APPD | | | |